

Manual Screen User Manual

Installation Method

Install the screen in the location where the audience can see the whole screen when it is fully extended.

The screen can be wall mounting or ceiling hanging, users can choose the most suitable method according to their needs. Insure the right equipment is used for whichever chosen method.

For wall mounting or ceiling hanging on a wooden surface, use $\varnothing 5 \times 60$ mm wood screws.

For wall mounting or ceiling hanging on a brick, concrete or plaster surface, use $\varnothing 6 \times 60$ mm screws with screw anchors or wall plugs.

Ceiling Mounting:

Measure the distance between D-rings, drill holes for screw hooks with the same distance apart, making sure the holes are in line with each other and parallel with the wall.

Screw the appropriate screw hooks into the holes and hang the screen by the D-rings.

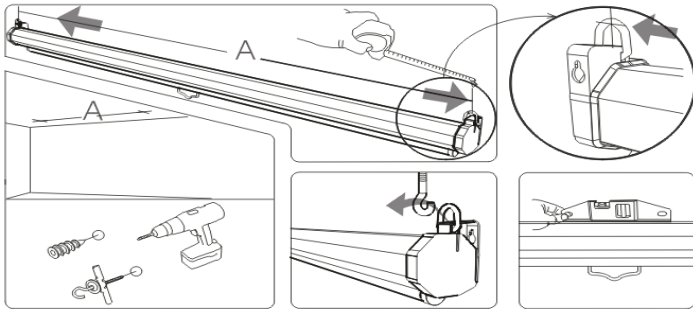

Ceiling hanging method

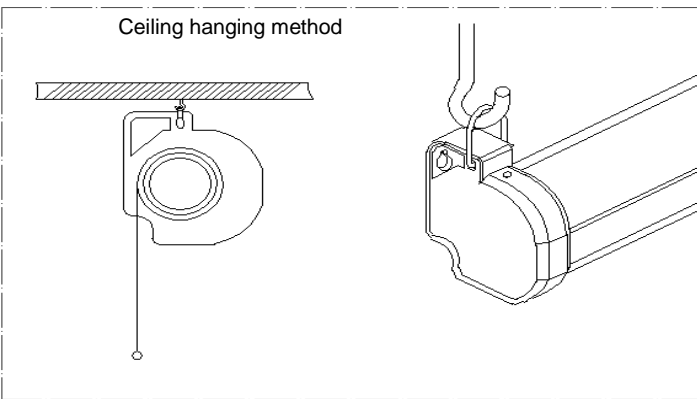

Wall Mounting:

Measure the distance from the holes in the wall mounting brackets, mark out the same distance on the wall and drill holes for the screws, making sure the holes are level. Screw an appropriate screw into each hole, hang the screen from the screws with the holes in the brackets. Check the screen is evenly spaced from the wall with a spirit level.

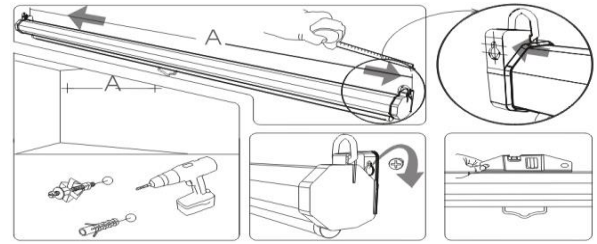

Wall mounting method

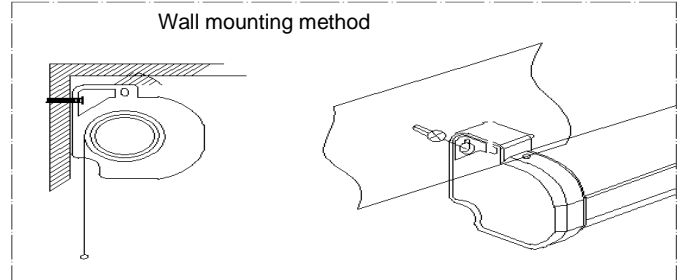

Screen Operation

TO LOWER THE PROJECTION SURFACE:

Pull the projection surface down to the desired length (Fig. 1); allowing the projection surface to retract a small amount will engage the locking mechanism.

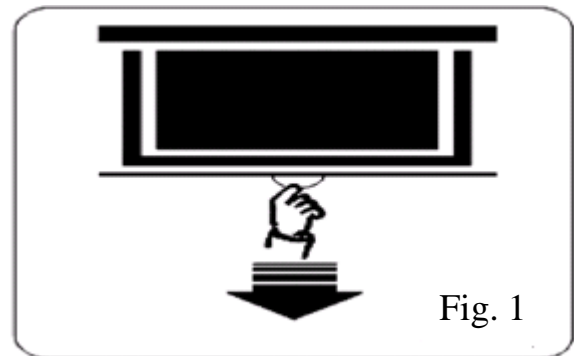

TO RAISE THE PROJECTION SURFACE:

Pulling the projection surface down a small amount will disengage the locking mechanism. (Fig. 2) Once the locking mechanism has been disengaged the projection surface will be pulled back into its case.

